

# TYPICAL LOT LAYOUT

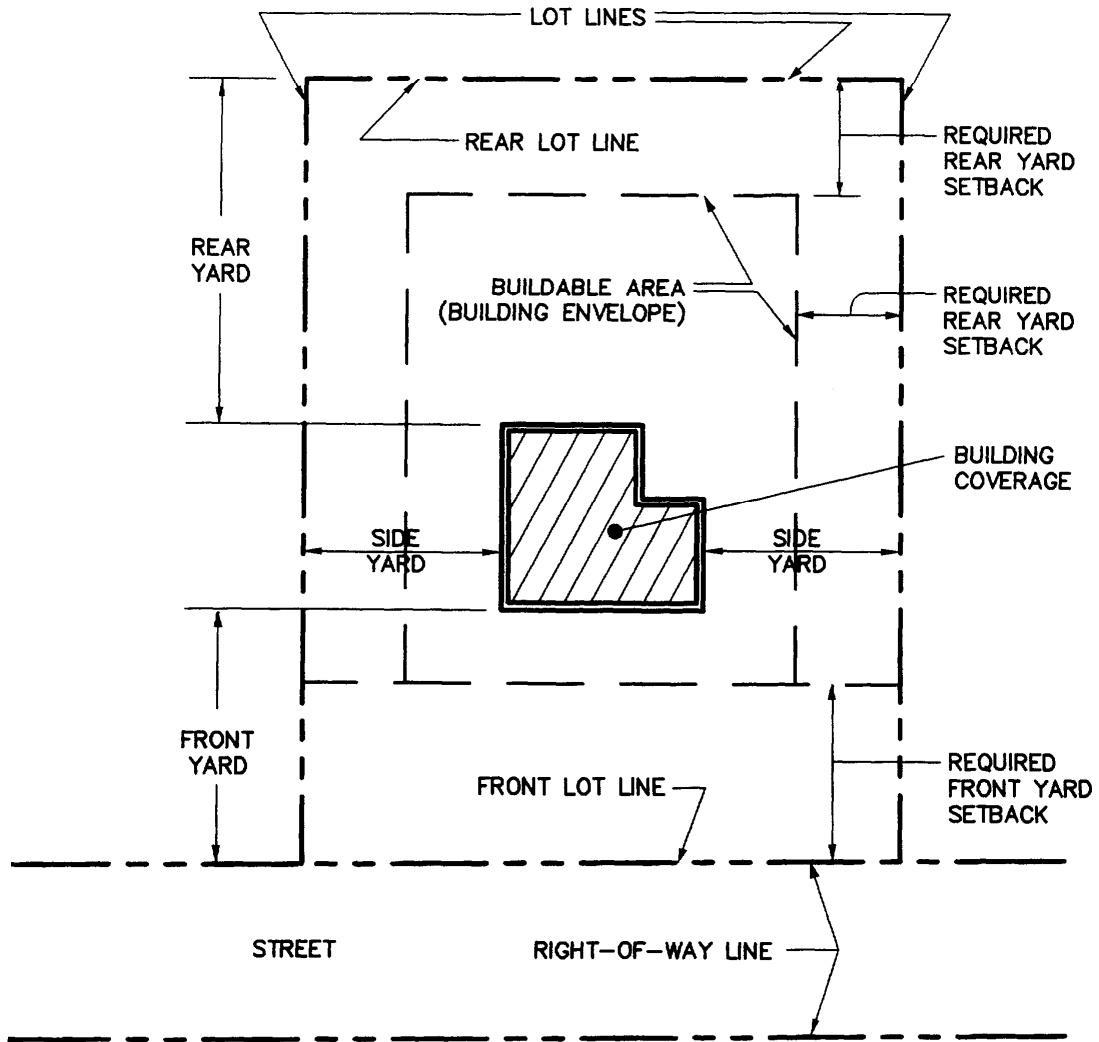

## TYPICAL STREET CROSS SECTION

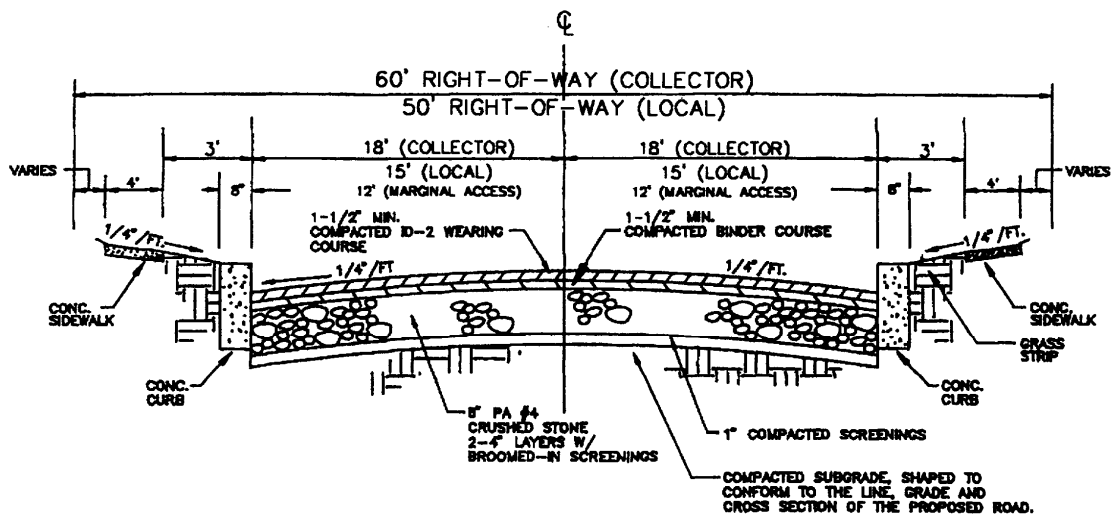

## SIGHT DISTANCE

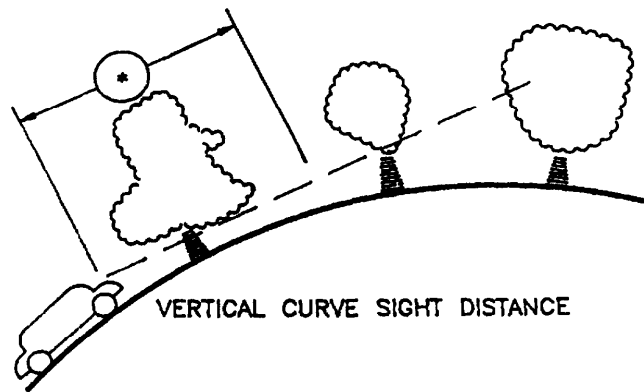
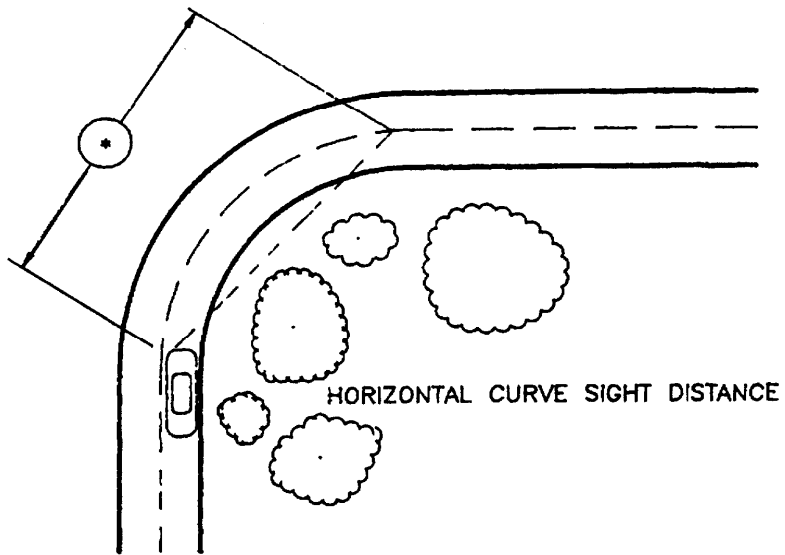

\* DISTANCE VARIES ACCORDING TO TYPE OF DEVELOPMENT

# CUL-DE-SAC STREETS

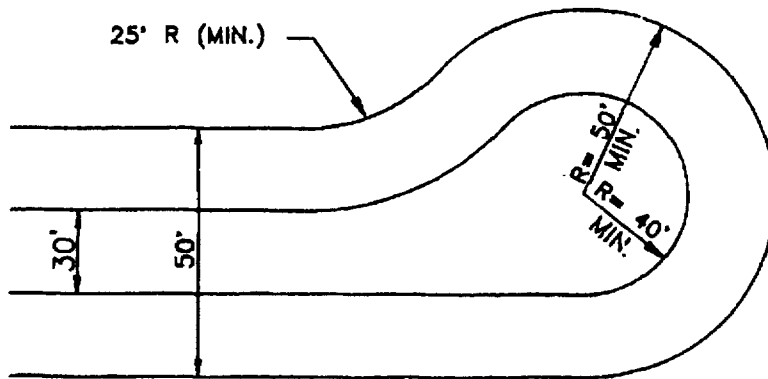

BULB TYPE

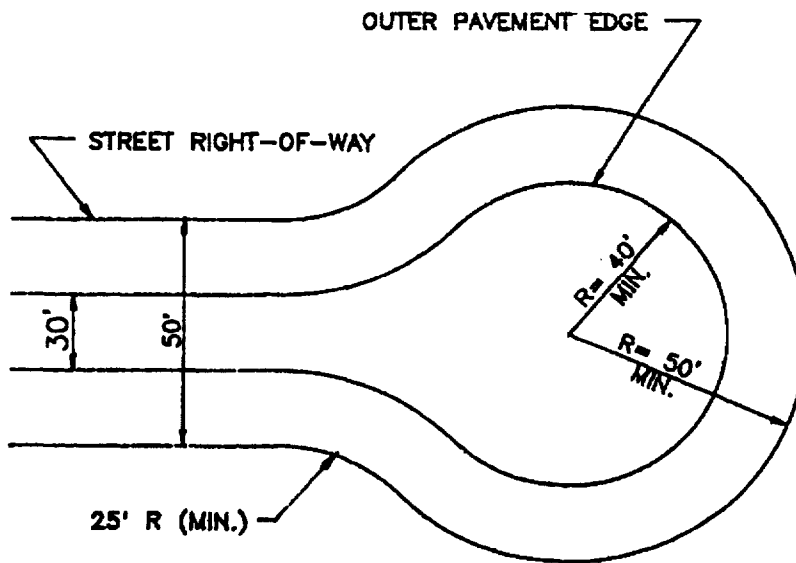

STANDARD TYPE

# CLEAR SIGHT TRIANGLE

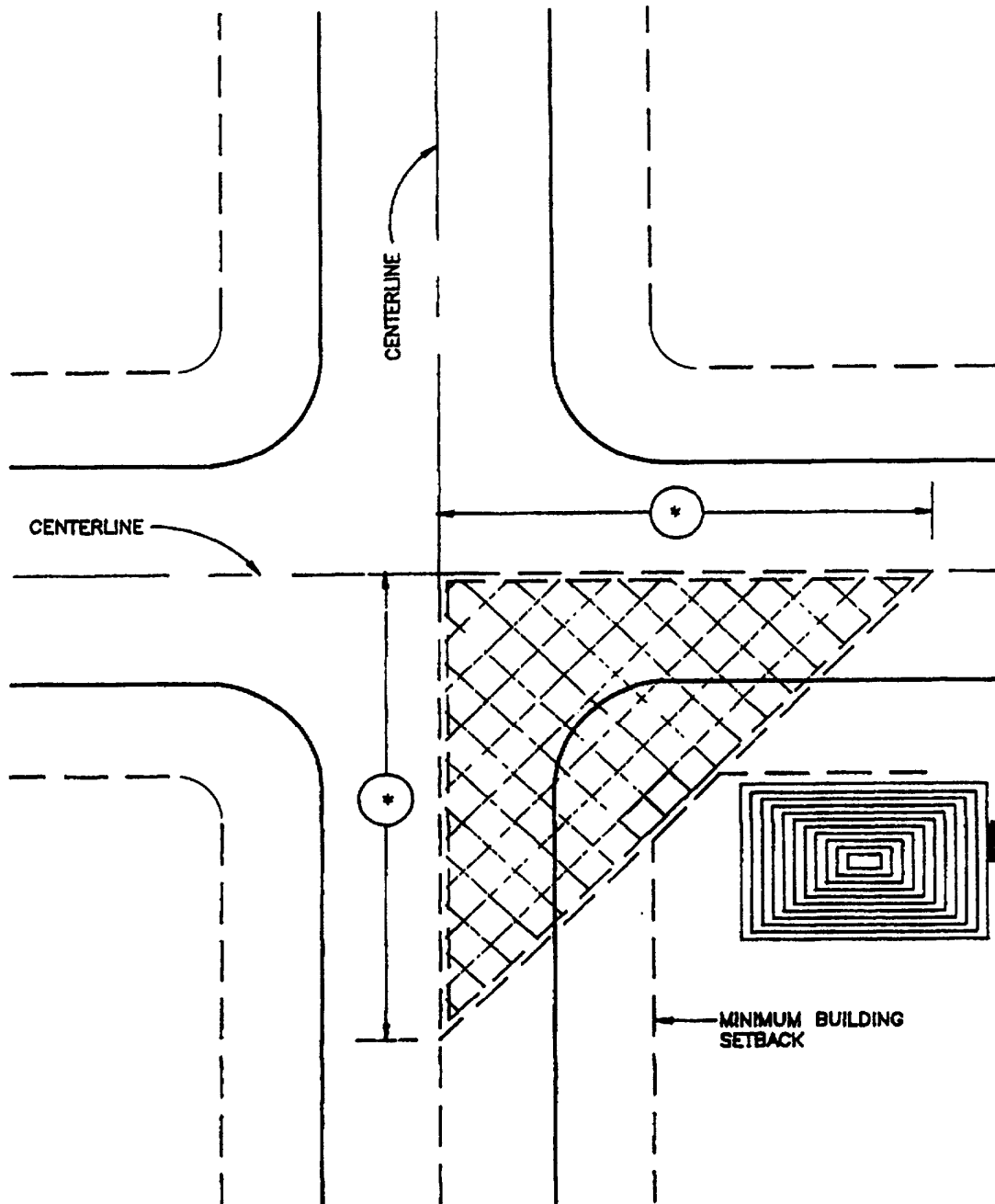

\* DISTANCE VARIES ACCORDING TO TYPE OF DEVELOPMENT

# CURB, SIDEWALK & DRIVEWAY DETAIL

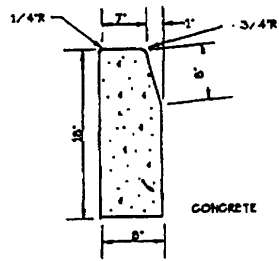

STANDARD STRAIGHT CURB

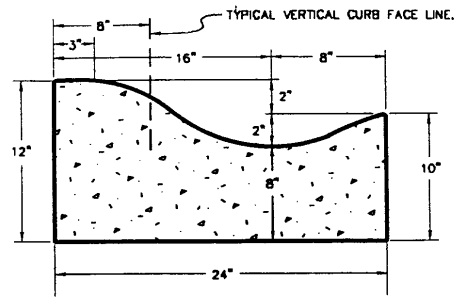

STANDARD ROLLED CURB

NOTE: ALL CONCRETE TO HAVE 3500 PSI COMPRESSIVE STRENGTH @ 28 DAYS

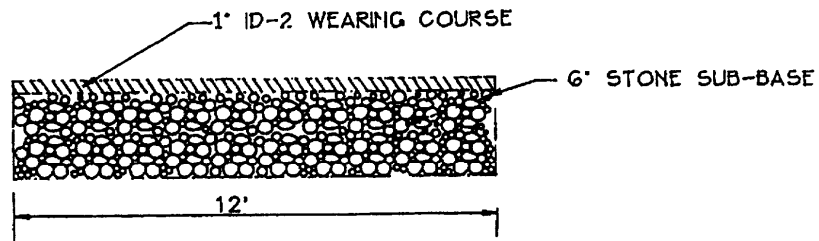

RESIDENTIAL DRIVEWAY DETAIL

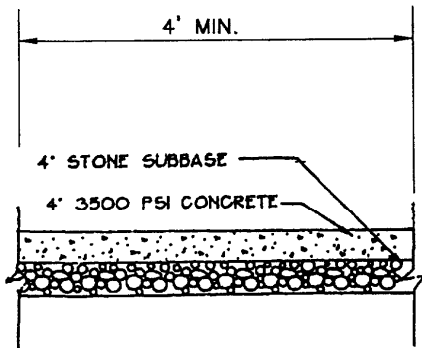

SIDEWALK DETAIL

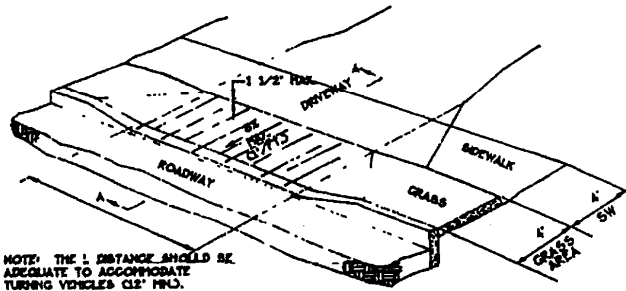

NOTE: THE 12\"/>

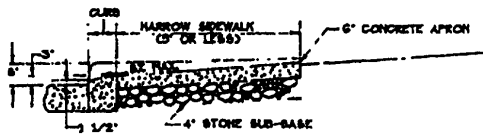

DEPRESSED CURB WITH APRON  
N.T.A.

# HANDICAPPED RAMP DETAIL

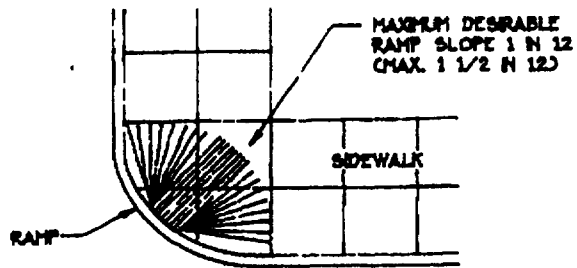

PLAN

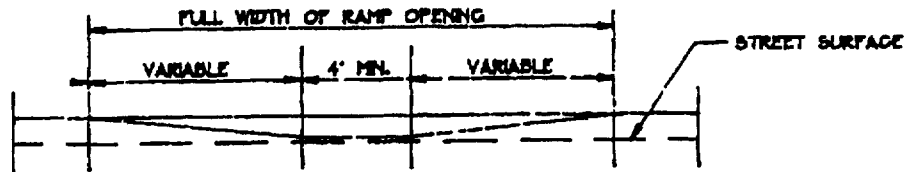

ELEVATION

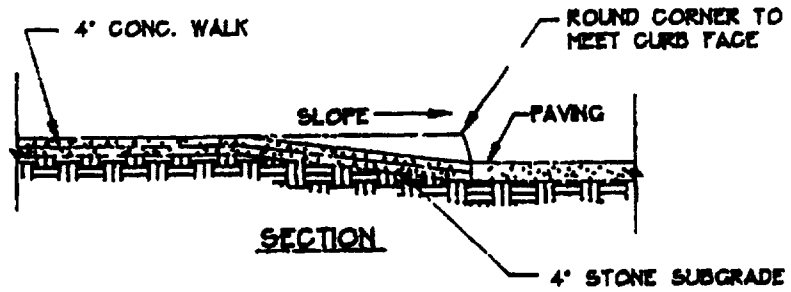

SECTION

# TRENCH RESTORATION DETAIL

NOTE: TEMPORARY TO BE MAINTAINED  
30 DAYS (MIN) 90 DAYS (MAX.)  
PRIOR TO PLACING PERMANENT

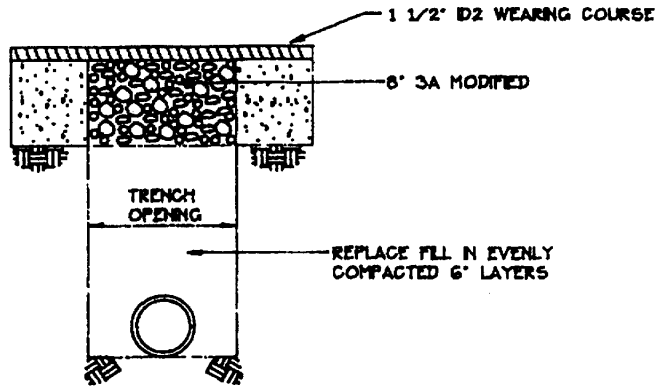

## TEMPORARY

N.T.S.

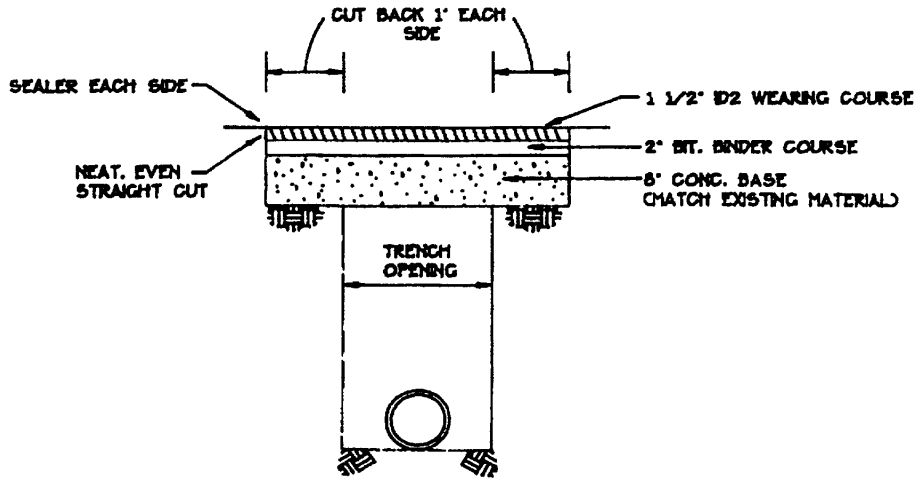

## PERMANENT

N.T.S.



**STANDARD BOROUGH SIGNATURE BLOCK**

<b>APPROVED</b>	
CHESTER HEIGHTS BOROUGH DELAWARE COUNTY, PA.	
Name of Development:	_____
Date:	_____
Borough Engineer:	_____
Planning Commission:	_____
	Chairman
	_____
	Member
Borough Council:	_____
	President
	_____
	Secretary

CHESTER HEIGHTS CODE

STANDARD NOTES FOR SUBDIVISION PLANS:

1. Acknowledgement:  
State of Pennsylvania  
County of Delaware

On this, the \_\_\_\_\_ day of \_\_\_\_\_, 19\_\_\_\_, before me  
the undersigned, personally appeared \_\_\_\_\_

\_\_\_\_\_, who being duly sworn  
according to law, deposes and says that he is the owner (or  
equitable owner) of the property shown on this plan, that the  
subdivision plan thereof was made at his direction and he  
acknowledges the same to be his act and plan and desires the  
same be recorded as such according to law.

Witness my hand and seal the day and date above written

\_\_\_\_\_  
(signature of owners)

\_\_\_\_\_  
(notary public or other officer)

My commission expires \_\_\_\_\_

Survey Statement

I hereby certify to \_\_\_\_\_, that to the best of my knowledge  
and belief, on this \_\_\_\_\_ day of \_\_\_\_\_, 19\_\_\_\_, this plat and survey  
were performed in accordance with the latest Minimum Standards for Boundary Surveys  
Section of the Manual of Practice for Professional Land Surveyors in the  
Commonwealth of Pennsylvania, as adopted by the Pennsylvania Society  
of Land Surveyors.

\_\_\_\_\_  
Signature of Surveyor

SEAL

\_\_\_\_\_  
Registration Number